

REVISIONS				
ZONE	REV	DESCRIPTION	DATE	APPRV
-	-	INITIAL ISSUE	-	-

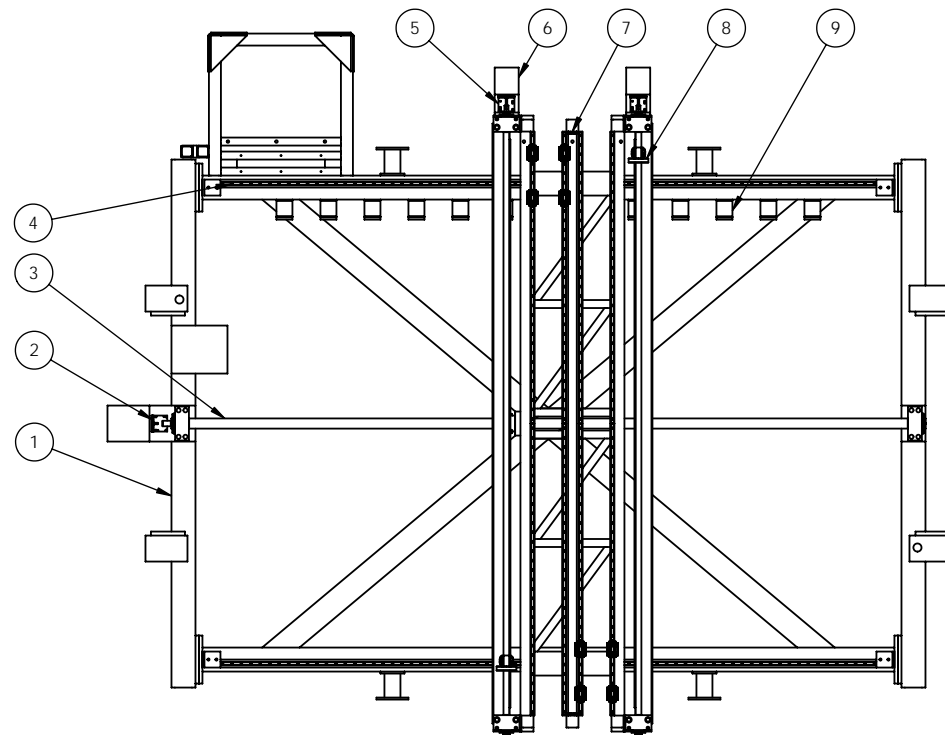
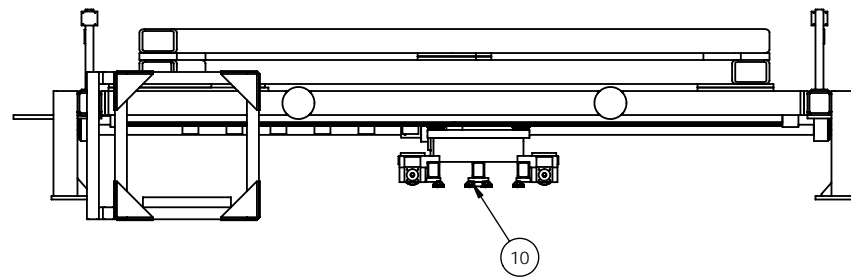
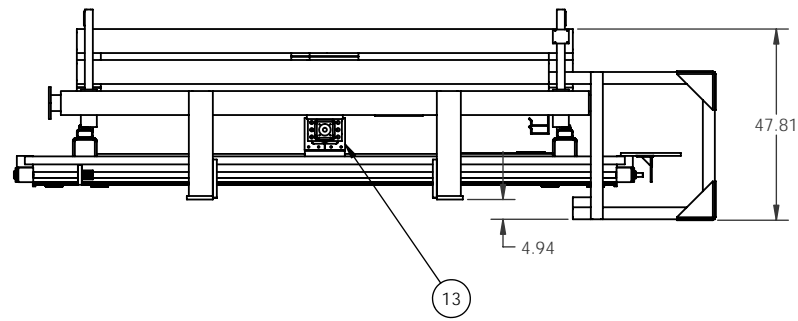
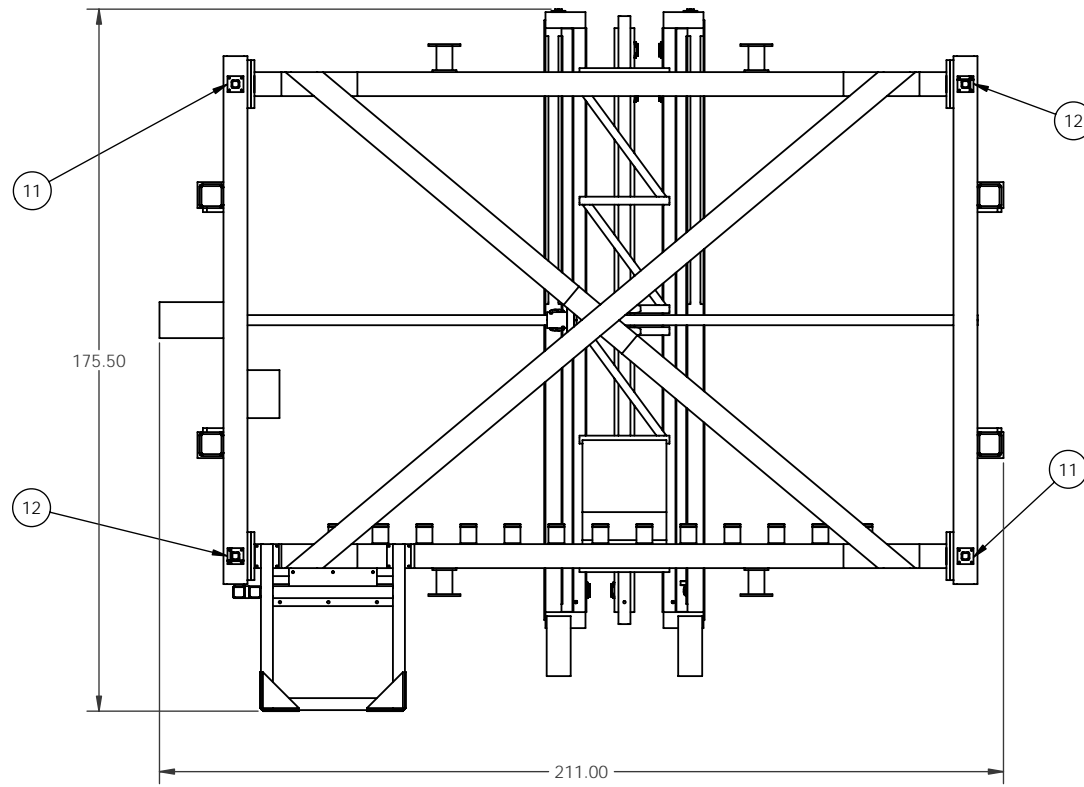

- NOTES:  
 1) ALL WELDS ARE FILLET, NOT SHOWN  
 2) ALL WELDS CONTINUOUS  
 3) PAINT ALL UNMACHINED SURFACES BLUE ENAMEL

Parts List						
ITEM NO.	QTY	DET_SHT	DESCRIPTION	MATERIAL	SIZE	WEIGHT
1	1	-	MAIN FRAME ASSY	SEE DWG #70002	-	5075
2	1	4	MOTOR BRACKET, LONG SCR	WELDMNT, SEE DETAIL	-	2.86
3	1	5	R-71 BALL SCREW	ROCKFORD BALL SCREW	SEE DETAIL	359
4	2	-	HSR25 HB 2 UU +4160L	THK	HSR25 HB 2 UU +4160L	34
5	2	6	MTR BRKT SHORT SCR	WELDMNT, SEE DETAIL	-	3.81
6	1	-	CROSS FRAME	SEE DWG #70003	-	1563
7	2	7	TRAVEL STOP	CRS	.63 x 1.13 x 2.00	0.29
8	2	8	SHORT SCREW ASSY	ROCKFORD BALL SCREW	SEE DETAIL	126
9	13	7	HANGER	WELDMNT, SEE DETAIL	-	3.86
10	4	-	HSR25 HB 2 UU +3700L	THK	HSR25 HB 2 UU +3700L	31
11	2	9	E-STOP POST, LH	WELDMNT, SEE DETAIL	-	10.61
12	2	10	E-STOP POST, RH	WELDMNT, SEE DETAIL	-	12.57
13	1	11	LONG SCR MOUNTING PLATE	CRS	.69 x 8.00 x 10.13	13

NOTE: DO NOT SCALE DRAWING !  
 ALL TOLERANCES UNLESS OTHERWISE SPECIFIED ARE  
 DIMENSIONS ARE IN:  
 ☒ INCHES [mm] ☐ mm [IN]  
 x.xxx [x,x] ± .010 [.3]  
 x.xxxx [x,xxx] ± .005 [.13]  
 x.xxxxx [x,xxxx] ± .0005 [.013]  
 xx/xx ± 1/32  
 x' ± 1"

UNIVERSITY OF ROCHESTER  
 DEPT. OF PHYSICS AND ASTRONOMY  
 SIDNEY W. BARNES RESEARCH LABORATORY

TITLE  
**MINERVA MAPPER ASS'Y**

THIRD ANGLE PROJECTION	DRAWN RSF	DATE 2/1/07
	CHECKED RSF	DATE 2/1/07
	APPROVED RSF	DATE -

THIS IS THE PROPERTY OF THE UNIVERSITY OF ROCHESTER. ANY USE OR REPRODUCTION WITHOUT AUTHORIZATION BY THIS UNIVERSITY IS PROHIBITED.

SIZE DWG NO	1	70001	REV	-
SCALE	1:10	SHEET 1 OF 11		

WEIGHT: 7564 LBS

1 FILE: 70001-MAPPER FAB ASSEMBLY

REVISIONS				
ZONE	REV	DESCRIPTION	DATE	APPRV
-	-	INITIAL ISSUE	-	-

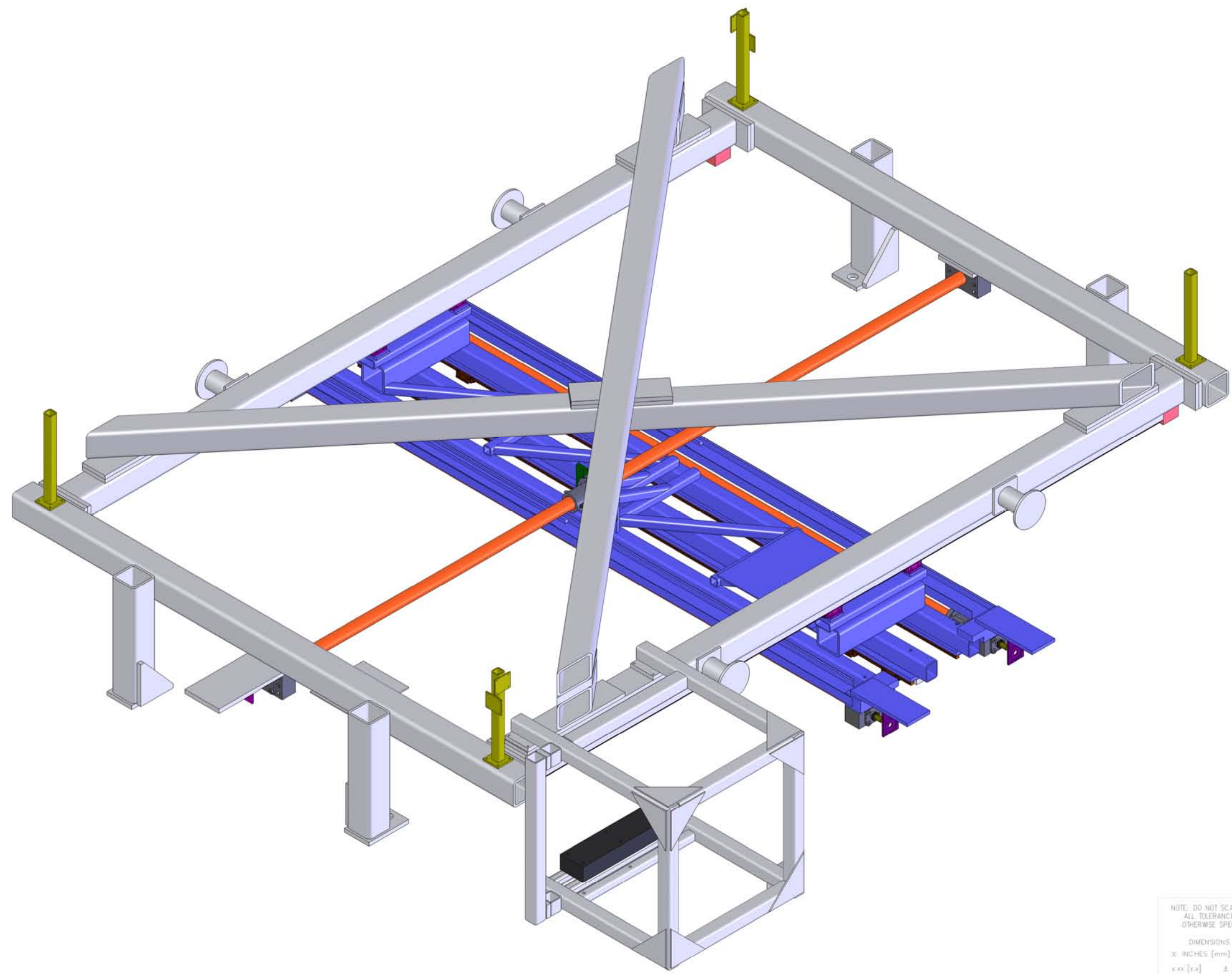

NOTE: DO NOT SCALE DRAWING!  
 ALL TOLERANCES UNLESS OTHERWISE SPECIFIED ARE

DIMENSIONS ARE IN:  
 IN: INCHES [mm]    MM: mm [IN]

x.xxx [x.x]    ± .010 [.3]  
 x.xx [x.xx]    ± .005 [.13]  
 x.xxxx [x.xxxx] ± .0005 [.013]  
 x.x/x    ± 1/32  
 x'    ± 1"

UNIVERSITY OF ROCHESTER  
 DEPT. OF PHYSICS AND ASTRONOMY  
 SIDNEY W. BARNES RESEARCH LABORATORY

TITLE: MINERVA MAPPER ASS'Y

THIRD ANGLE PROJECTION

DRAWN	RSF	DATE	2/1/07
CHECKED	RSF	DATE	2/1/07
APPROVED	RSF	DATE	-

THIS IS THE PROPERTY OF THE UNIVERSITY OF ROCHESTER. ANY USE OR REPRODUCTION WITHOUT AUTHORIZATION BY THIS UNIVERSITY IS PROHIBITED.	SIZE	DWG NO	REV
	D	70001	-
WEIGHT: 7564 LBS	SCALE	SHEET	2 OF 11
	1:10	2	

1 FILE: 70001-MAPPER FAB ASSEMBLY

REVISIONS				
ZONE	REV	DESCRIPTION	DATE	APPRV
-	-	INITIAL ISSUE	-	-

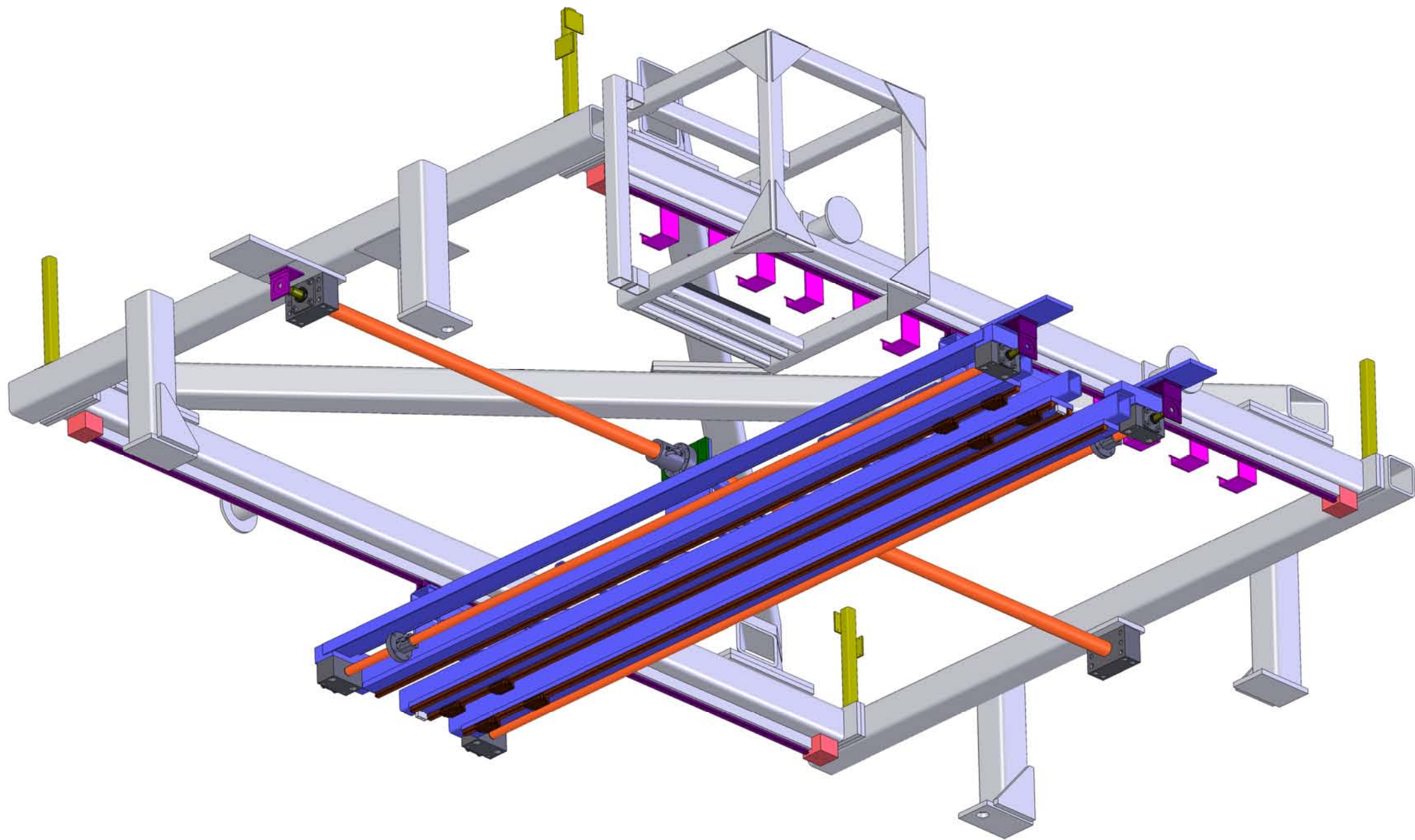

NOTE: DO NOT SCALE DRAWING!  
ALL TOLERANCES UNLESS OTHERWISE SPECIFIED ARE

DIMENSIONS ARE IN:  
X: INCHES [mm]    □: mm [IN]

x.xx [x.x]    ± .010 [.3]  
x.xxx [x.xx]    ± .005 [.13]  
x.xxxx [x.xxxx]    ± .0005 [.013]  
xx/xx    ± 1/32  
x'    ± 1'

UNIVERSITY OF ROCHESTER  
DEPT. OF PHYSICS AND ASTRONOMY  
SIDNEY W. BARNES RESEARCH LABORATORY

TITLE: MINERVA MAPPER ASS'Y

THIRD ANGLE PROJECTION

DRAWN	RSF	DATE	2/1/07
CHECKED	RSF	DATE	2/1/07
APPROVED	RSF	DATE	-

THIS IS THE PROPERTY OF THE UNIVERSITY OF ROCHESTER. ANY USE OR REPRODUCTION WITHOUT AUTHORIZATION BY THIS UNIVERSITY IS PROHIBITED.

SIZE	DWG NO	REV
D	70001	-
SCALE	1:10	SHEET 3 OF 11

WEIGHT: 7564 LBS

1 FILE: 70001-MAPPER FAB ASSEMBLY

REVISIONS				
ZONE	REV	DESCRIPTION	DATE	APPRV
-	-	INITIAL ISSUE	-	-

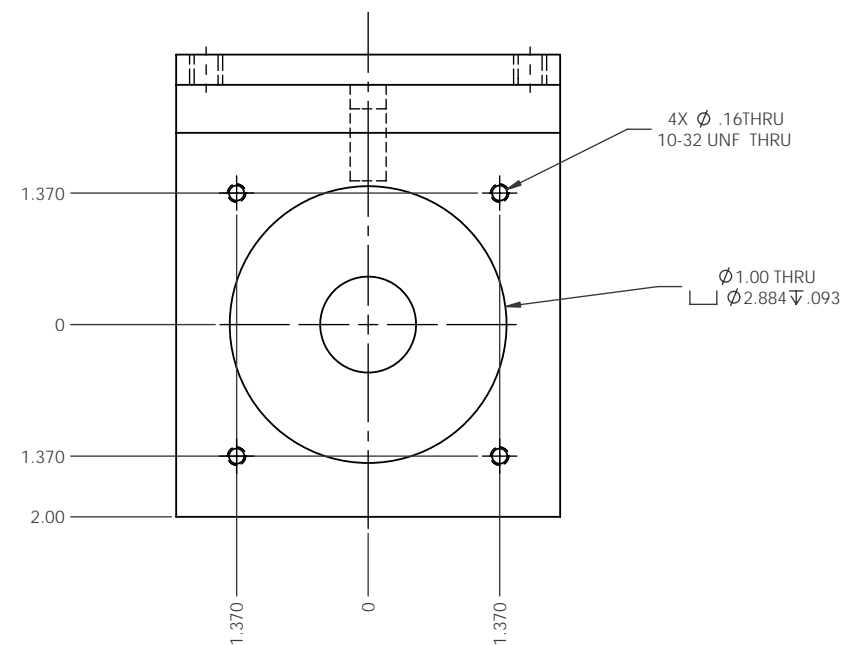
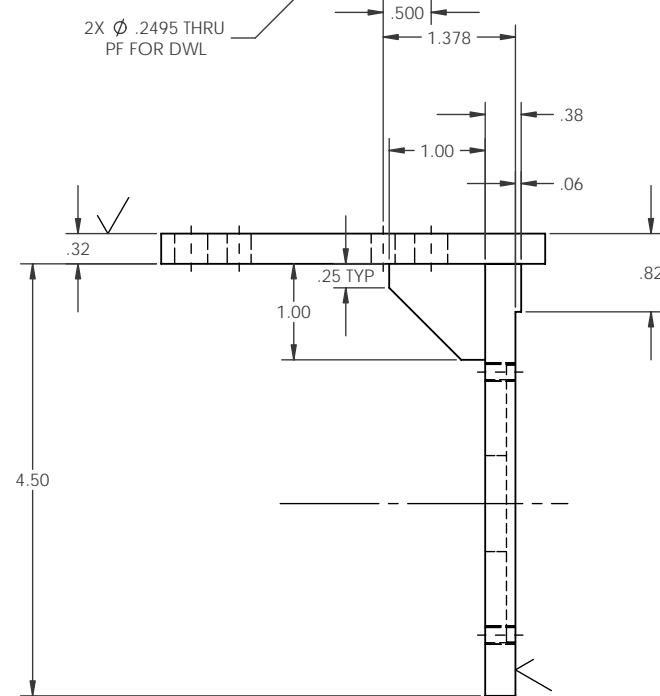
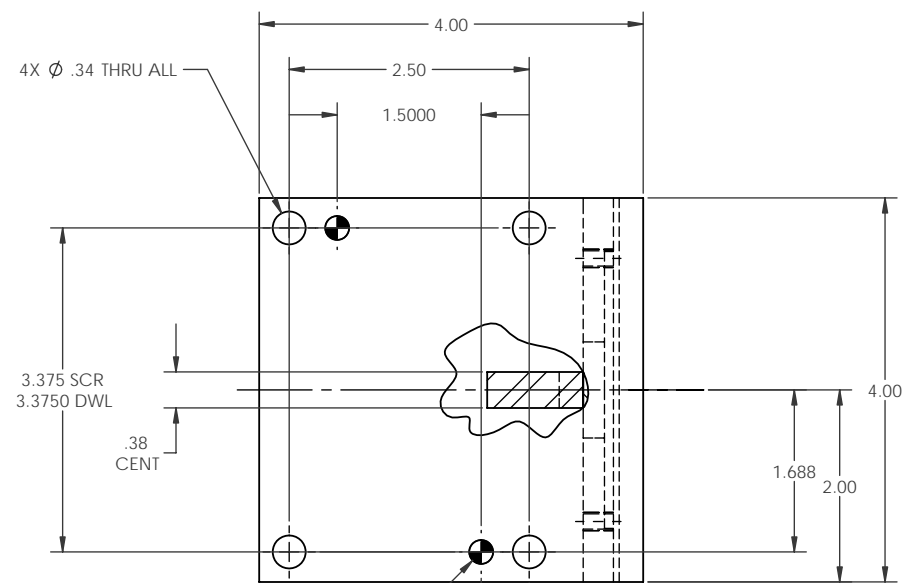

2 NAME: MTR BRKT LONG SCR  
 QTY: 1  
 MAT'L: WELDMENT, SEE DETAIL  
 HARD'N: -  
 FINISH: PAINT PER SPEC  
 SIZE/TYPER: -  
 WEIGHT: 2.86

NOTES:  
 1) ALL WELDS ARE FILLET, NOT SHOWN  
 2) ALL WELDS CONTINUOUS  
 3) PAINT ALL UNMACHINED SURFACES BLUE ENAMEL

Weldment Cut List					
ITEM NO.	QTY.	MATERIAL	DESCRIPTION	LENGTH	WEIGHT
1	1	CRS	.38 X 1.00	1.00	0.08
2	1	CRS	.32 X 4.00	4.00	1.38
3	1	CRS	.38 x 4.00	4.50	1.40

NOTE: DO NOT SCALE DRAWING !  
 ALL TOLERANCES UNLESS OTHERWISE SPECIFIED ARE

DIMENSIONS ARE IN:  
 INCHES [mm]  mm [IN]

x.xxx [x.x] ± .010 [.3]  
 x.xxxx [x.xxx] ± .005 [.13]  
 x.xxxxx [x.xxxx] ± .0005 [.013]  
 xx/xx ± 1/32  
 x' ± 1"

UNIVERSITY OF ROCHESTER  
 DEPT. OF PHYSICS AND ASTRONOMY  
 SIDNEY W. BARNES RESEARCH LABORATORY

TITLE: MINERVA MAPPER ASS'Y

THIRD ANGLE PROJECTION

DRAWN	RSF	DATE	2/1/07
CHECKED	RSF	DATE	2/1/07
APPROVED	RSF	DATE	-

THIS IS THE PROPERTY OF THE UNIVERSITY OF ROCHESTER. ANY USE OR REPRODUCTION WITHOUT AUTHORIZATION BY THIS UNIVERSITY IS PROHIBITED.

SCALE: 1:1 SHEET 4 OF 11

WEIGHT: 2.86 LBS

1 FILE: 70001-MAPPER FAB ASSEMBLY

REVISIONS				
ZONE	REV	DESCRIPTION	DATE	APPRV
-	-	INITIAL ISSUE	-	-

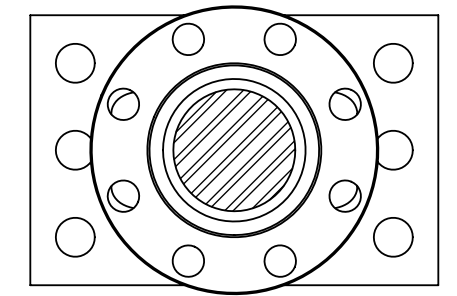
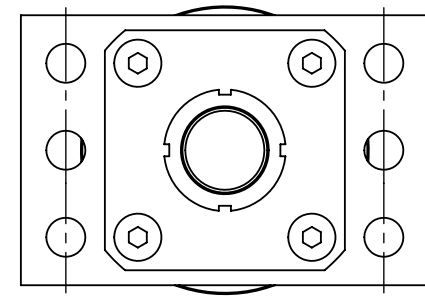
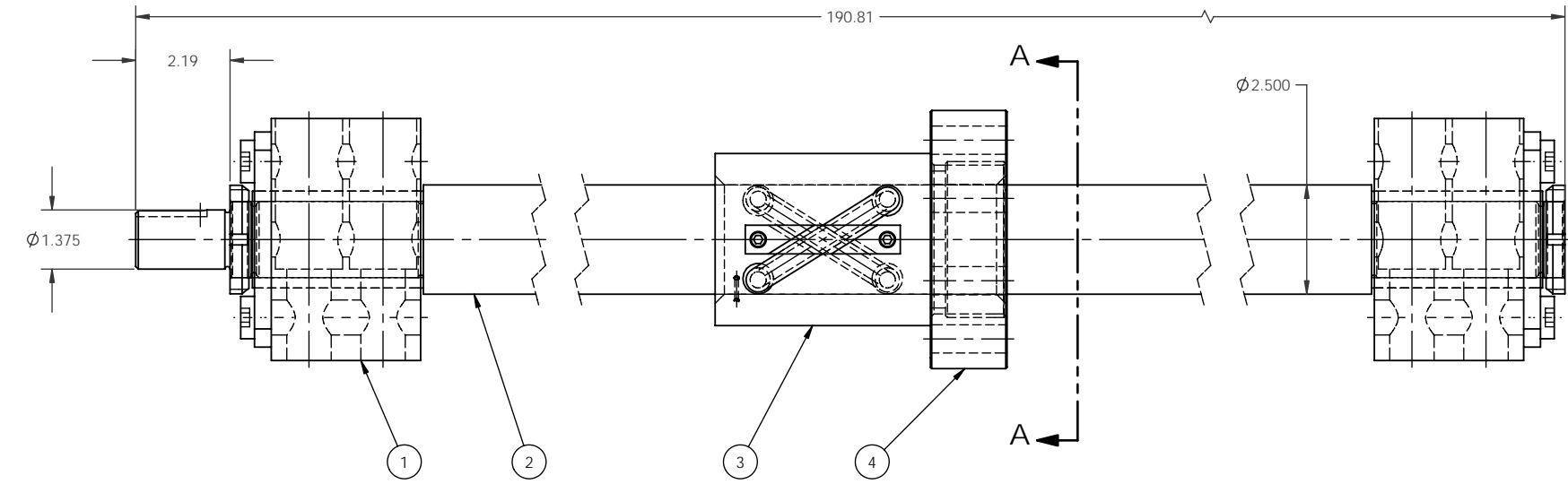
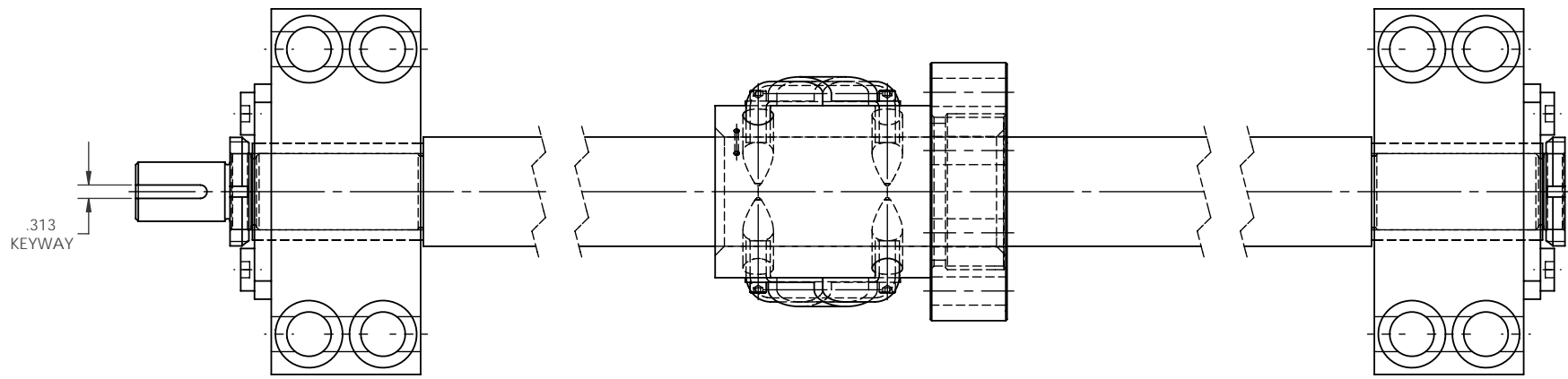

SECTION A-A

3 NAME: R-71 BALL SCREW  
 QTY: 1  
 MAT'L: ROCKFORD BALL SCREW  
 HARD'N: -  
 FINISH: -  
 SIZE/TYPE: BM-45PER QUOTE #285437  
 WEIGHT: 359

SUPPLIER NOTES:  
 1) 190.81" AOL, QUOTE#285437  
 2) 2.50" DIA, 1.00" RH LEAD  
 3) PURCHASE COMPLETE ASSEMBLY

Parts List						
ITEM NO.	QTY	PART NUMBER	DESCRIPTION	MATERIAL	SIZE	WEIGHT
1	2	BM-45	BM-45 BEARING MOUNT	ROCKFORD BALLSCREW	BM-45	41
2	1	LONG SCR R-71	LONG SCREW, R-71	ROCKFORD BALLSCREW	2.500" DIA, 1.00" PITCH, RH	257
3	1	LONG SCR BALLNUT	LONG SCR BALLNUT	ROCKFORD BALLSCREW	2.500" DIA	13
4	1	LONG SCR FLGNUT	LONG SCR FLGNUT	ROCKFORD BALLSCREW	2.500" DIA	8

NOTE: DO NOT SCALE DRAWING !  
 ALL TOLERANCES UNLESS OTHERWISE SPECIFIED ARE  
 DIMENSIONS ARE IN:  
 INCHES [mm]  mm [IN]  
 x.xxx [x.x] ± .010 [.3]  
 x.xxxx [x.xxx] ± .005 [.13]  
 x.xxxxx [x.xxxx] ± .0005 [.013]  
 xx/xx ± 1/32  
 x' ± 1"

UNIVERSITY OF ROCHESTER  
 DEPT. OF PHYSICS AND ASTRONOMY  
 SIDNEY W. BARNES RESEARCH LABORATORY

TITLE: MINERVA MAPPER ASS'Y

THIRD ANGLE PROJECTION

DRAWN	RSF	DATE	2/1/07
CHECKED	RSF	DATE	2/1/07
APPROVED	RSF	DATE	-

THIS IS THE PROPERTY OF THE UNIVERSITY OF ROCHESTER. ANY USE OR REPRODUCTION WITHOUT AUTHORIZATION BY THIS UNIVERSITY IS PROHIBITED.

SCALE 1:2 SHEET 5 OF 11

WEIGHT: 359 LBS

1 FILE: 70001-MAPPER FAB ASSEMBLY

REVISIONS				
ZONE	REV	DESCRIPTION	DATE	APPRV
-	-	INITIAL ISSUE	-	-

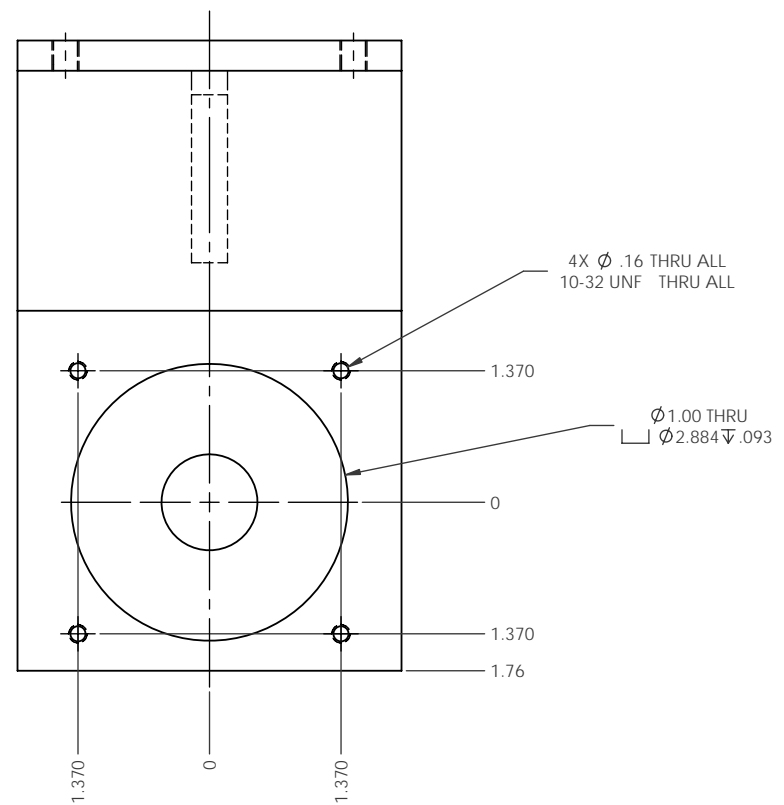
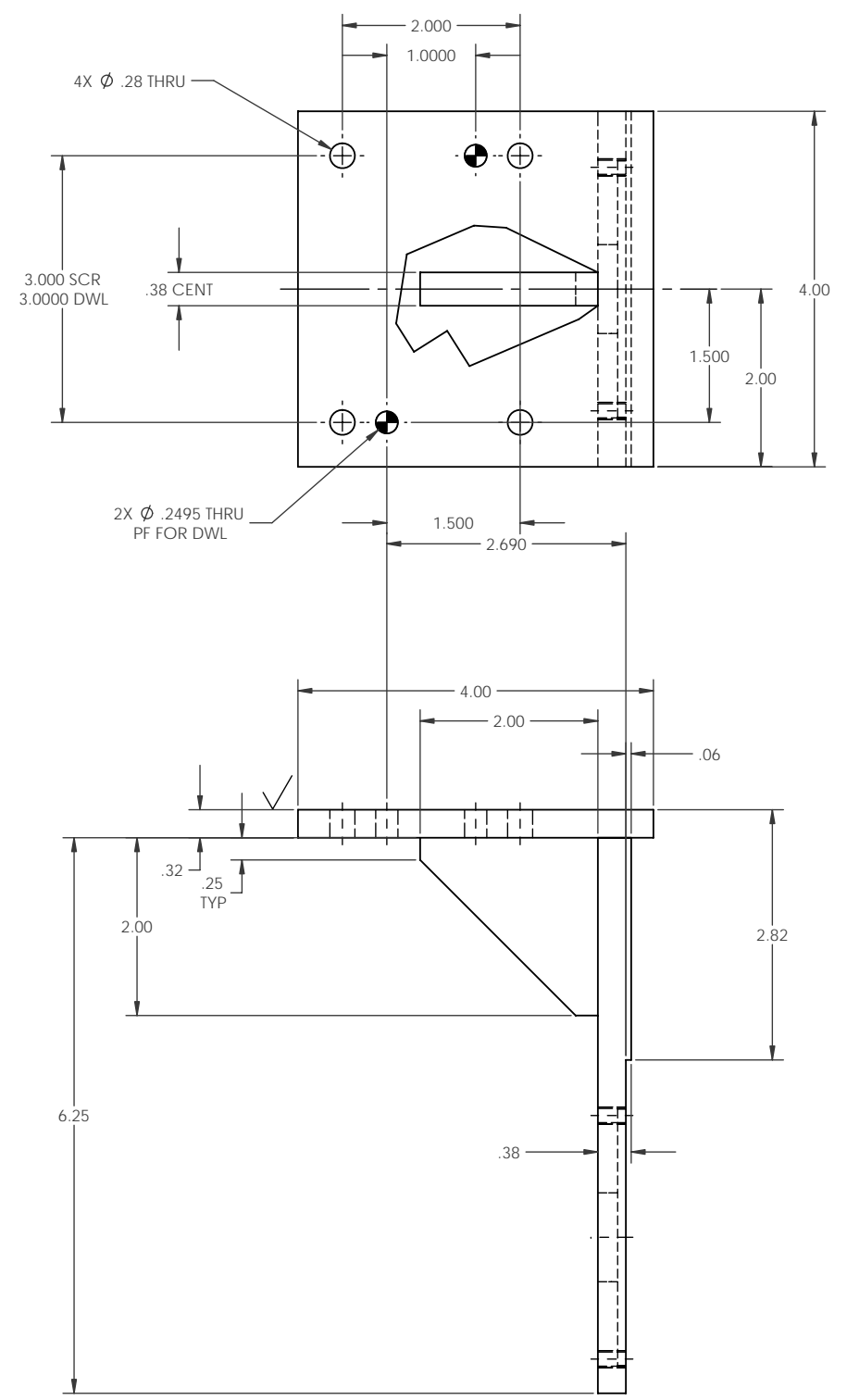

5 NAME: MTR BRKT SHORT SCR  
 QTY: 2  
 MAT'L: WELDMENT, SEE DETAIL  
 HARD'N: -  
 FINISH: PAINT PER SPEC  
 SIZE/TYP: -  
 WEIGHT: 3.81

Weldment Cut List					
ITEM NO.	QTY.	MATERIAL	DESCRIPTION	LENGTH	WEIGHT
1	1	CRS	.38 x 2.00	2.00	0.26
2	1	CRS	.38 x 4.00	6.25	2.16
3	1	CRS	.32 x 4.00	4.00	1.39

NOTES:  
 1) ALL WELDS ARE FILLET, NOT SHOWN  
 2) ALL WELDS CONTINUOUS  
 3) PAINT ALL UNMACHINED SURFACES BLUE ENAMEL

NOTE: DO NOT SCALE DRAWING !  
 ALL TOLERANCES UNLESS OTHERWISE SPECIFIED ARE

DIMENSIONS ARE IN:  
 INCHES [mm]  mm [IN]

x.xxx [x.x]  $\pm$  .010 [.3]  
 x.xxxx [x.xxx]  $\pm$  .005 [.13]  
 x.xxxxx [x.xxxx]  $\pm$  .0005 [.013]  
 xx/xx  $\pm$  1/32  
 x'  $\pm$  1"

UNIVERSITY OF ROCHESTER  
 DEPT. OF PHYSICS AND ASTRONOMY  
 SIDNEY W. BARNES RESEARCH LABORATORY

TITLE: MINERVA MAPPER ASS'Y

THIRD ANGLE PROJECTION

DRAWN	RSF	DATE	2/1/07
CHECKED	RSF	DATE	2/1/07
APPROVED	RSF	DATE	-

THIS IS THE PROPERTY OF THE UNIVERSITY OF ROCHESTER. ANY USE OR REPRODUCTION WITHOUT AUTHORIZATION BY THIS UNIVERSITY IS PROHIBITED.

SCALE: 1:1 SHEET 6 OF 11

WEIGHT: 3.81 LBS

1 FILE: 70001-MAPPER FAB ASSEMBLY

REVISIONS				
ZONE	REV	DESCRIPTION	DATE	APPRV
-	-	INITIAL ISSUE	-	-

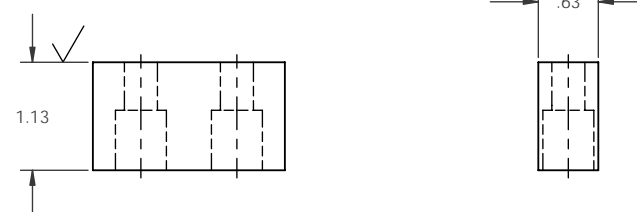
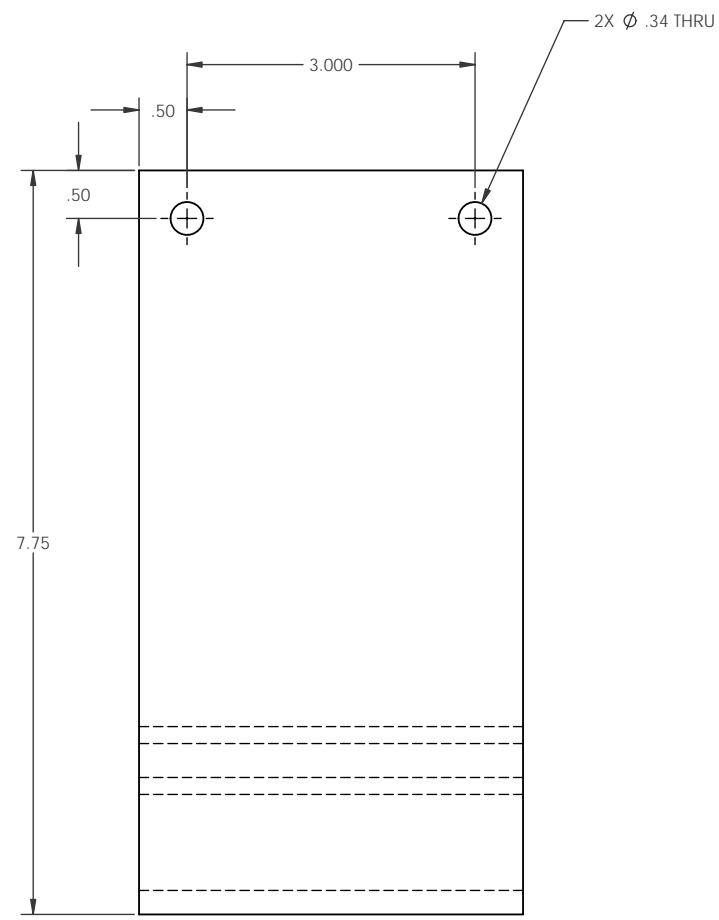
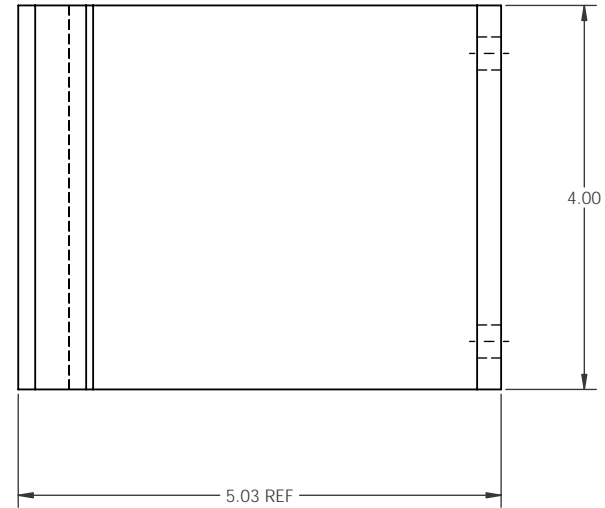
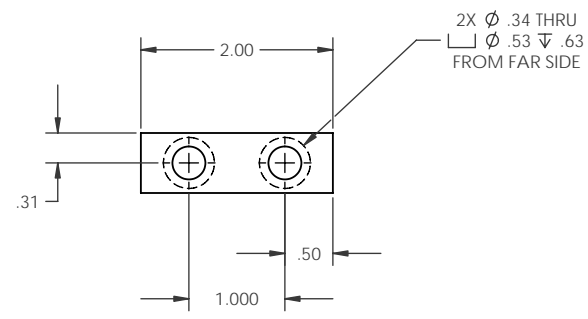

NOTES:  
1) PAINT ALL UNMACHINED SURFACES BLUE ENAMEL

7 NAME: TRAVEL STOP  
QTY: 2  
MAT'L: CRS  
HARD'N: -  
FINISH: PAINT PER SPEC  
SIZE/TYPE: .63 x 1.13 x 2.00  
WEIGHT: 0.29

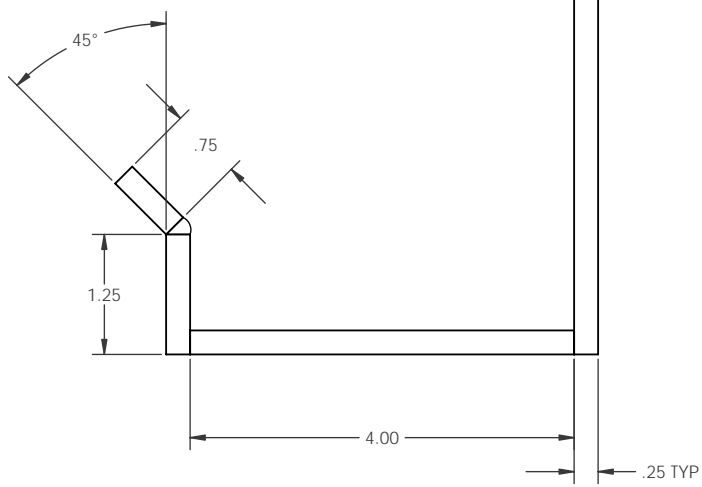

9 NAME: HANGER  
QTY: 13  
MAT'L: WELDMENT, SEE CHART  
HARD'N: -  
FINISH: PAINT PER SPEC  
SIZE/TYPE: -  
WEIGHT: 3.86

Weldment Cut List					
ITEM NO.	QTY.	MATERIAL	DESCRIPTION	LENGTH	WEIGHT
1	1	CRS	.25 x 4.00	7.75	2.17
2	1	CRS	.25 x 4.00	4.00	1.13
3	1	CRS	.25 x 1.25	4.00	0.35
4	1	CRS	.25 x .75	4.00	0.21

NOTES:  
1) ALL WELDS ARE FILLET, NOT SHOWN  
2) ALL WELDS CONTINUOUS  
3) PAINT ALL UNMACHINED SURFACES BLUE ENAMEL

NOTE: DO NOT SCALE DRAWING !  
ALL TOLERANCES UNLESS OTHERWISE SPECIFIED ARE  
DIMENSIONS ARE IN:  
☑ INCHES [mm] ☐ mm [IN]  
x.xxx [x.x] ± .010 [.3]  
x.xxxx [x.xxx] ± .005 [.13]  
x.xxxxx [x.xxxx] ± .0005 [.013]  
xx/xx ± 1/32  
x' ± 1'

UNIVERSITY OF ROCHESTER  
DEPT. OF PHYSICS AND ASTRONOMY  
SIDNEY W. BARNES RESEARCH LABORATORY

TITLE: MINERVA MAPPER ASS'Y

THIRD ANGLE PROJECTION

DRAWN	RSF	DATE	2/1/07
CHECKED	RSF	DATE	2/1/07
APPROVED	RSF	DATE	-

THIS IS THE PROPERTY OF THE UNIVERSITY OF ROCHESTER. ANY USE OR REPRODUCTION WITHOUT AUTHORIZATION BY THIS UNIVERSITY IS PROHIBITED.

SCALE: 1:1 SHEET: 7 OF 11

WEIGHT: 0.29 LBS

1 FILE: 70001-MAPPER FAB ASSEMBLY

REVISIONS					
ZONE	REV	DESCRIPTION	DATE	APPRV	
-	-	INITIAL ISSUE	-	-	-

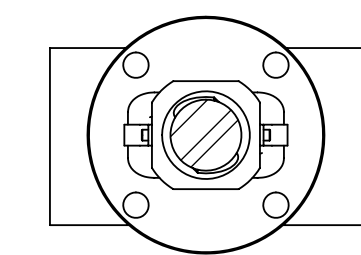
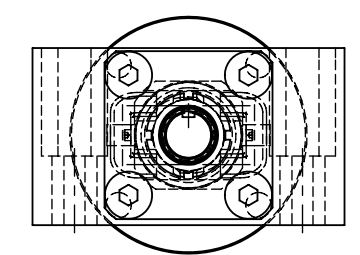
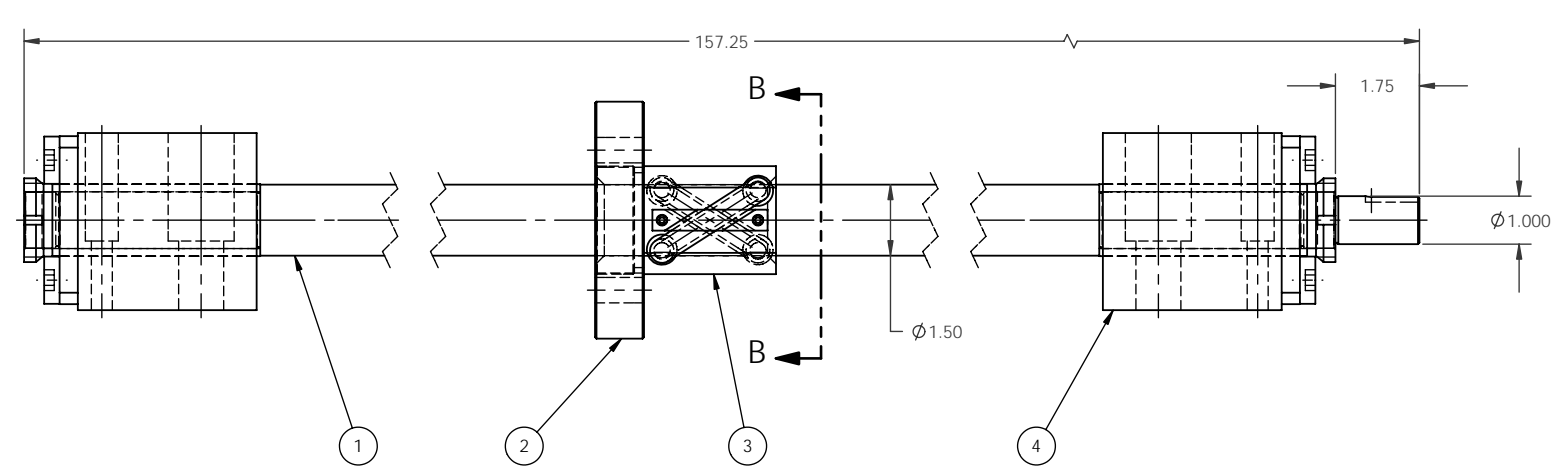
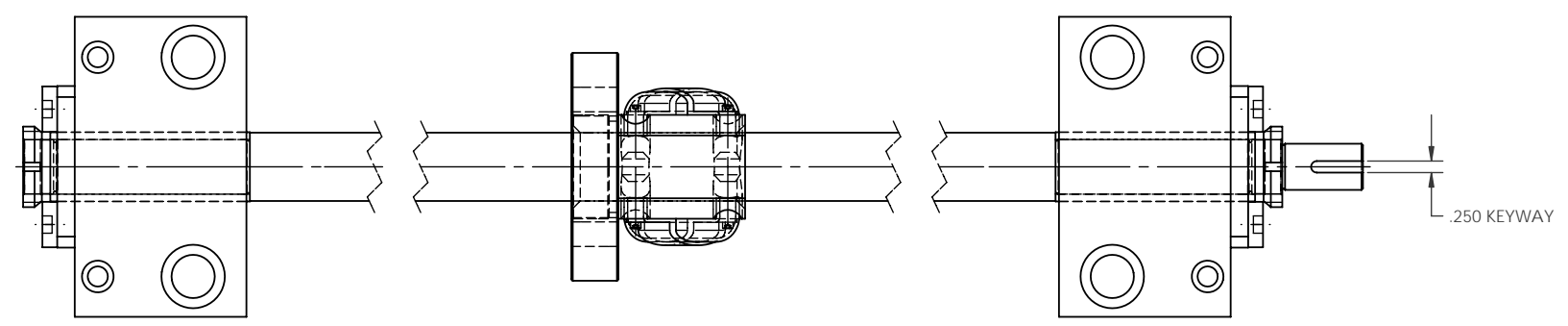

SECTION B-B

8 NAME: R-55 BALLSCREW  
 QTY: 2  
 MAT'L: ROCKFORD BALLSCREW  
 HARD'N: -  
 FINISH: -  
 SIZE/TYPER: PER QUOTE #285437  
 WEIGHT: 126

SUPPLIER NOTES:  
 1) 157.25" AOL, QUOTE#285437  
 2) 1.50" DIA, 1.00" RH LEAD  
 3) PURCHASE COMPLETE ASSEMBLY

Parts List					
ITEM NO.	QTY	DESCRIPTION	MATERIAL	SIZE	WEIGHT
1	1	SHORT BALLSCREW, R-55	ROCKFORD BALLSCREW	1.500" DIA, 1.00" PITCH, RH	71
2	1	SHORT SCR, FLGNUT	ROCKFORD BALLSCREW	1.500" DIA	4
3	1	SHORT SCR BALLNUT	ROCKFORD BALLSCREW	1.500" DIA	3
4	2	BEARING MOUNT	ROCKFORD BALLSCREW	BMF-30	24

NOTE: DO NOT SCALE DRAWING!  
 ALL TOLERANCES UNLESS OTHERWISE SPECIFIED ARE:  
 DIMENSIONS ARE IN:  
 INCHES [mm]  mm [IN]  
 x.xxx [x,x] ± .010 [.3]  
 x.xxxx [x,xxx] ± .005 [.13]  
 x.xxxxx [x,xxxx] ± .0005 [.013]  
 xx/xx ± 1/32  
 x' ± 1"

UNIVERSITY OF ROCHESTER  
 DEPT. OF PHYSICS AND ASTRONOMY  
 SIDNEY W. BARNES RESEARCH LABORATORY

TITLE: MINERVA MAPPER ASS'Y

THIRD ANGLE PROJECTION

DRAWN	RSF	DATE	2/1/07
CHECKED	RSF	DATE	2/1/07
APPROVED	RSF	DATE	-

THIS IS THE PROPERTY OF THE UNIVERSITY OF ROCHESTER. ANY USE OR REPRODUCTION WITHOUT AUTHORIZATION BY THIS UNIVERSITY IS PROHIBITED.

SCALE	1:2	SHEET	8	OF	11
SIZE	DWG NO	70001	REV	-	



REVISIONS				
ZONE	REV	DESCRIPTION	DATE	APPRV
-	-	INITIAL ISSUE	-	-

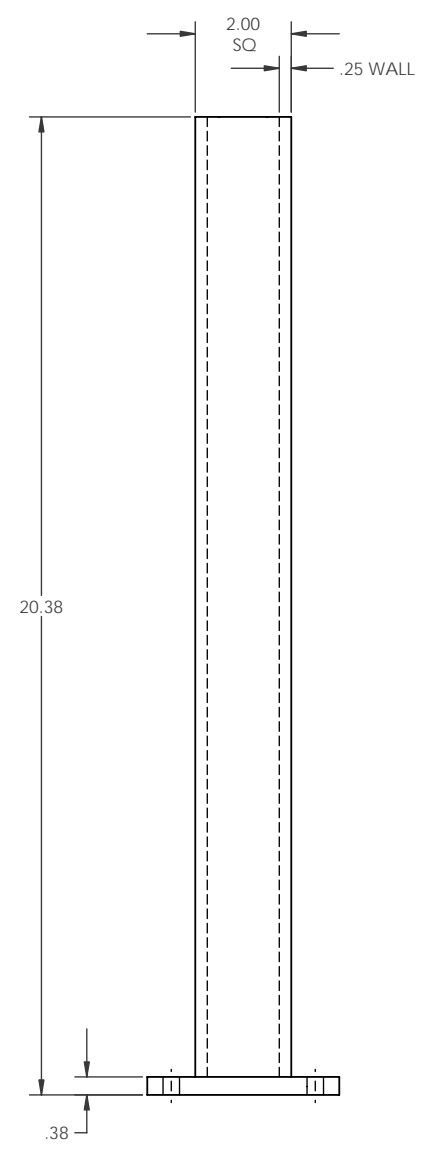
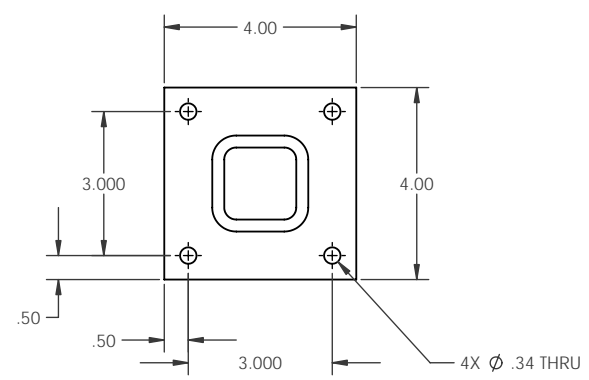

11 NAME: E-STOP POST LH  
 QTY: 1  
 MAT'L: WELDMENT, SEE DETAIL  
 HARD'N: -  
 FINISH: PAINT PER SPEC  
 SIZE/TYPE: -  
 WEIGHT: 10.61

Weldment Cut List					
ITEM NO.	QTY.	MATERIAL	DESCRIPTION	LENGTH	WEIGHT
1	1	STEEL	TUBE, SQUARE 2.00 X 2.00 X .25	20	31.78
2	1	CRS	.38 X 4.00	4.00	1.65

NOTES:  
 1) ALL WELDS ARE FILLET, NOT SHOWN  
 2) ALL WELDS CONTINUOUS  
 3) PAINT ALL UNMACHINED SURFACES BLUE ENAMEL

NOTE: DO NOT SCALE DRAWING !  
 ALL TOLERANCES UNLESS OTHERWISE SPECIFIED ARE  
 DIMENSIONS ARE IN:  
 INCHES [mm]  mm [IN]  
 x.xx [x,x] ± .010 [.3]  
 x.xxx [x,xx] ± .005 [.13]  
 x.xxxx [x,xxx] ± .0005 [.013]  
 xx/xx ± 1/32  
 x' ± 1"

UNIVERSITY OF ROCHESTER  
 DEPT. OF PHYSICS AND ASTRONOMY  
 SIDNEY W. BARNES RESEARCH LABORATORY

TITLE: MINERVA MAPPER ASS'Y

THIRD ANGLE PROJECTION

DRAWN	RSF	DATE	2/1/07
CHECKED	RSF	DATE	2/1/07
APPROVED	RSF	DATE	-

THIS IS THE PROPERTY OF THE UNIVERSITY OF ROCHESTER. ANY USE OR REPRODUCTION WITHOUT AUTHORIZATION BY THIS UNIVERSITY IS PROHIBITED.

SCALE: 1:2 SHEET: 9 OF 11

WEIGHT: 10.61 LBS

1 FILE: 70001-MAPPER FAB ASSEMBLY

REVISIONS				
ZONE	REV	DESCRIPTION	DATE	APPRV
-	-	INITIAL ISSUE	-	-

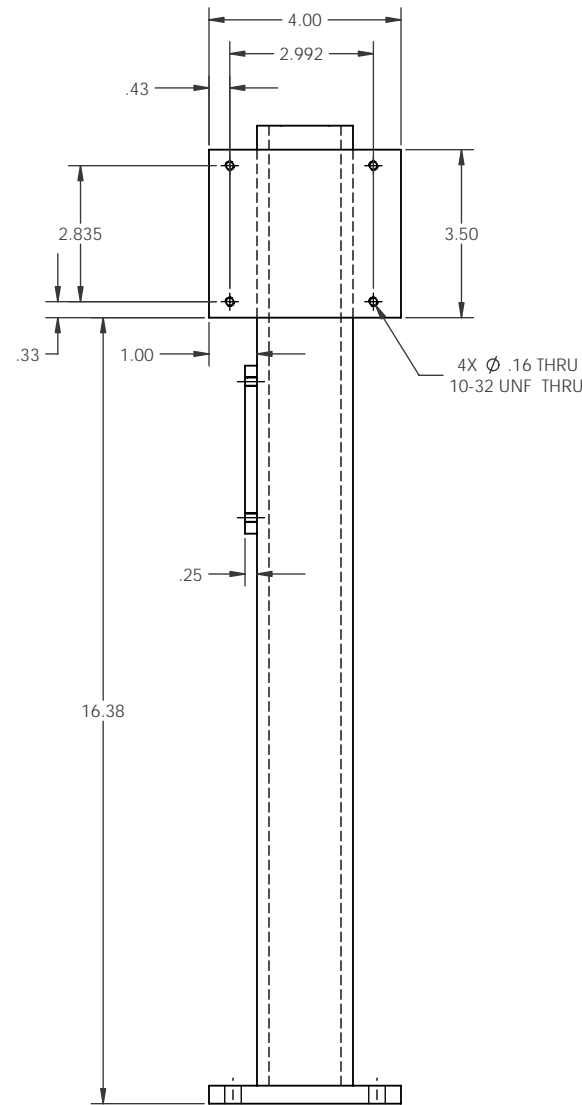
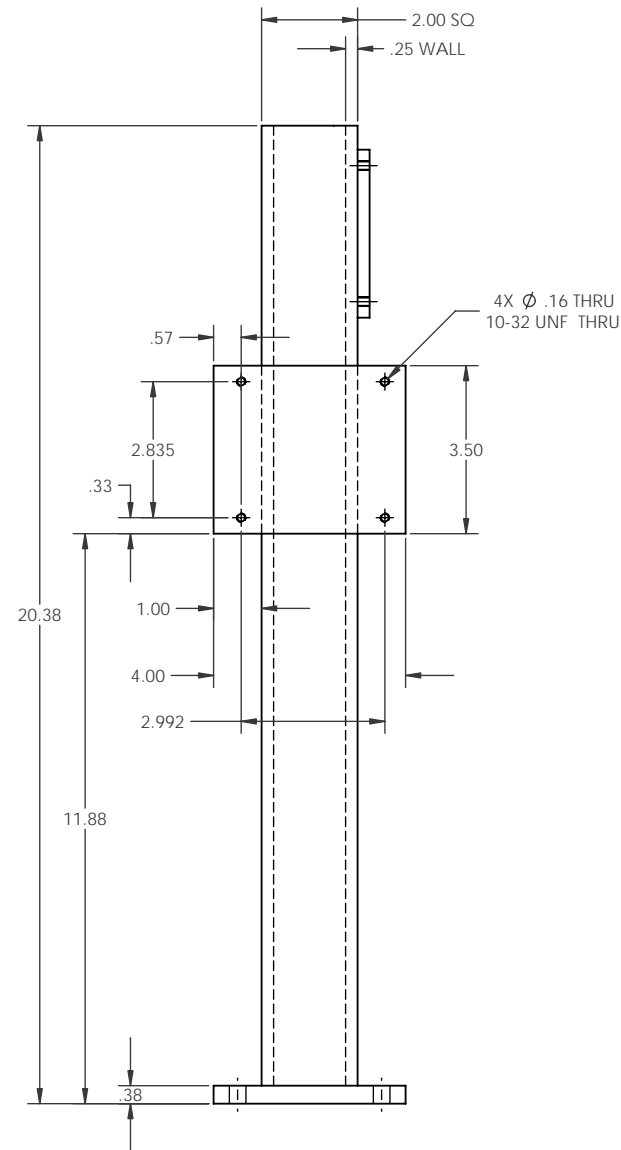
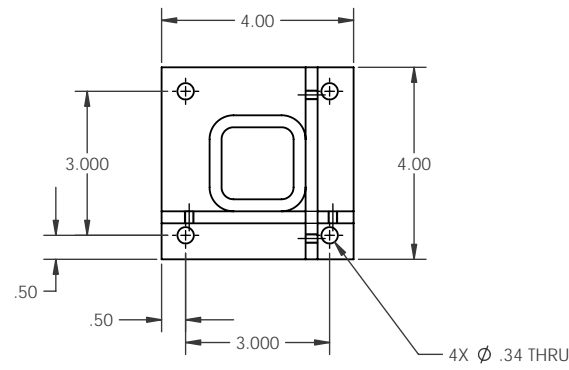

12 NAME: E-STOP POST RH  
 QTY: 1  
 MAT'L: WELDMENT, SEE DETAIL  
 HARD'N: -  
 FINISH: PAINT PER SPEC  
 SIZE/TYPER: -  
 WEIGHT: 12.57

Weldment Cut List					
ITEM NO.	QTY.	MATERIAL	DESCRIPTION	LENGTH	WEIGHT
1	1	STEEL	TUBE, SQUARE 2.00 X 2.00 X .25	20	8.96
2	1	CRS	.38 x 4.00	4.00	1.65
3	2	CRS	.25 x 3.50	4.00	3.48

NOTES:  
 1) ALL WELDS ARE FILLET, NOT SHOWN  
 2) ALL WELDS CONTINUOUS  
 3) PAINT ALL UNMACHINED SURFACES BLUE ENAMEL

NOTE: DO NOT SCALE DRAWING !  
 ALL TOLERANCES UNLESS OTHERWISE SPECIFIED ARE  
 DIMENSIONS ARE IN:  
 ☒ INCHES [mm] ☐ mm [IN]  
 x.xxx [x.x] ± .010 [.3]  
 x.xxxx [x.xxx] ± .005 [.13]  
 x.xxxxx [x.xxxx] ± .0005 [.013]  
 xx/xx ± 1/32  
 x' ± 1'

UNIVERSITY OF ROCHESTER  
 DEPT. OF PHYSICS AND ASTRONOMY  
 SIDNEY W. BARNES RESEARCH LABORATORY

TITLE: MINERVA MAPPER ASS'Y

THIRD ANGLE PROJECTION

DRAWN	RSF	DATE	2/1/07
CHECKED	RSF	DATE	2/1/07
APPROVED	RSF	DATE	-

THIS IS THE PROPERTY OF THE UNIVERSITY OF ROCHESTER. ANY USE OR REPRODUCTION WITHOUT AUTHORIZATION BY THIS UNIVERSITY IS PROHIBITED.

SCALE 1:2 SHEET 10 OF 11

WEIGHT: 12.57 LBS

1 FILE: 70001-MAPPER FAB ASSEMBLY

REVISIONS				
ZONE	REV	DESCRIPTION	DATE	APPRV
-	-	INITIAL ISSUE	-	-

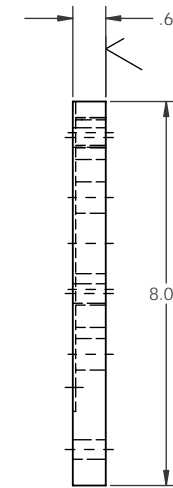
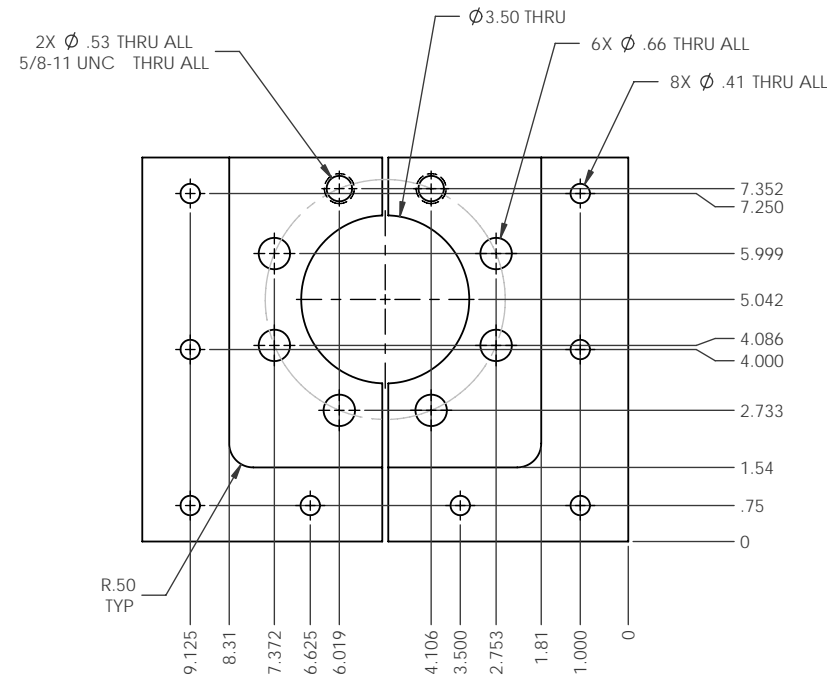
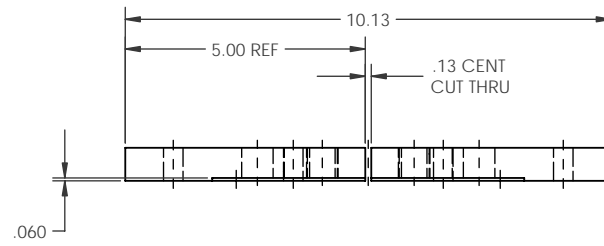

13 NAME: LONG SCR MOUNTING PLATE  
 QTY: 1  
 MATL: CRS  
 HARDN:  
 FINISH: PAINT PER SPEC  
 SIZE/TY: .69 x 8.00 x 10.13  
 WEIGHT: 13

NOTES:  
 1) PAINT ALL UNMACHINED SURFACES BLUE ENAMEL

NOTE: DO NOT SCALE DRAWING !  
 ALL TOLERANCES UNLESS OTHERWISE SPECIFIED ARE  
 DIMENSIONS ARE IN:  
 INCHES [mm]  mm [IN]  
 x.xx [x,x] ± .010 [.3]  
 x.xxx [x,xx] ± .005 [.13]  
 x.xxxx [x,xxx] ± .0005 [.013]  
 xx/xx ± 1/32  
 x' ± 1"

UNIVERSITY OF ROCHESTER  
 DEPT. OF PHYSICS AND ASTRONOMY  
 SIDNEY W. BARNES RESEARCH LABORATORY

TITLE: MINERVA MAPPER ASS'Y

THIRD ANGLE PROJECTION

DRAWN	RSF	DATE	2/1/07
CHECKED	RSF	DATE	2/1/07
APPROVED	RSF	DATE	-

THIS IS THE PROPERTY OF THE UNIVERSITY OF ROCHESTER. ANY USE OR REPRODUCTION WITHOUT AUTHORIZATION BY THIS UNIVERSITY IS PROHIBITED.

SIZE	DWG NO	REV
D	70001	-
SCALE	SHEET	OF
1:2	11	11

WEIGHT: 13 LBS

1 FILE: 70001-MAPPER FAB ASSEMBLY